



**16619 Aldine Westfield Road  
Houston, Texas 77032 USA  
Tel: 832.467.9898  
Fax: 832.467.9897  
e-mail: [sales@FluidSystems.com](mailto:sales@FluidSystems.com)**

**[www.FluidSystems.com](http://www.FluidSystems.com)**

Rev 060114



# TABLE OF CONTENTS

Company Profile	4
Shale Shakers	6
Quick Screen Panel Change	7
Cascade Systems	8
Replace-A-Bed	10
Flow Line Dividers	10
G Force Meter/Vibration Analyser	11
One-Lift Skid Unit	12
Mud CLeaner (Conditioners)	12
the HP eLIMIATOR	12
Hydrocyclones	14
Desanders	14
Desilters	14
Vacuum Degassers	15
Atmospheric Degassers	15
Mud Gas Separators	16
Centrifugal Pumps	17
Mud Agitators	18
Mud Guns	19
Standard Mud Hoppers	19
Mud Room Equipment	20
Bulk Silos	20
Dust Recovery Systems	20
Dust Free Mixing Systems	21
Big Bag Handling Systems	21
Caustic Soda Mixers	22
Shear Mixers	22
Pressure Washers	23
Vibrator Motors	23
Shaker Cuttings Driers	24
Vertical Cuttings Driers	25
Screw CONveyors (augers)	26
Vacuum Systems	26
Shaker Cuttings Drier Systems	27
Trailer Centrifuge Dewatering Systems	28
Dewatering Systems	29
Centrifuges	30
Complete Mud Systems	31
SAM State of the Art Mud Systems	33
Screen Panels	34

# *Fluid Systems Inc.*

## Our Vision

To achieve excellence in our endeavors  
and make a difference in the industry  
through our contributions.

## Our Mission

To provide our customers the highest  
standards of quality and service,  
through teamwork and personal  
dedication, above and beyond  
their expectations.

# COMPANY PROFILE

Fluid Systems, Inc. (FSI) began operations in early 1979 doing developmental and engineering work on solids control equipment and mud handling systems used on drilling rigs. The company has been involved in furthering solids control technology for the oil industry since its inception. The first type of equipment introduced was a line of mud cleaners (hydrocyclones mounted over shaker screens) which incorporated the use of linear motion in their design. In the early 1980's, FSI was one of the first companies to introduce Linear Motion Shakers, which have become the principal type of shakers in use on drilling rigs today and was tagged by rig supervisors as a "rough neck friendly" equipment. We developed a line of screen panels made from the highest quality screen designed using our proprietary mesh software for high liquid throughput, the maximum open area and optimum screen life using our state-of-the-art facility. Our computerized accelerometer testing allows our engineers to verify panel support and rigidity. We have earned a reputation for quality, service, dependability and equipment reliability around the world.

Fluid Systems, Inc. is now a worldwide provider of solids control, screening, waste management and process technology to the Oil & Gas, Industrial, Environmental and Mining Industries. We can customize your needs on zero discharge systems, dredging systems, solids/liquid separation, filtration systems, micro tunnelling, waste water processing, fine solids and sizing separation, agricultural systems, dewatering and HDD Systems. Our equipment innovations include side-mounted high-'G' vibrators, WedgeLok™ fasteners and pre-tensioned screen panels – all of which are being incorporated by competitors today. Single Panel, Dual Panel, Triple Panel, Quad Panel, and Five Panel Units are all available for varying process applications. Cascading Systems (Shaker-Over-Shaker) are available for special applications where the footprint for installation is restricted. FSI's engineering department is always looking forward to the next challenge, the next project, the next opportunity and the next frontier.



**Ben Hiltl - President , CEO**



**Pete Hoffmann - Vice-President**



SHALE SHAKERS

We achieved the "BALANCED LINEAR and ELIPTICAL MOTION" with the aid of the latest Solidworks®, AutoCAD® and Autodesk Inventor® which can pin point the center of gravity of the basket wherein we positioned the vibrators to deliver the maximum "G" Force during heavy loading. Its easy to adjust "G" Force counterweights and can also achieve a well designed vibration for optimum performance. Such simplicity and balance can shorten the laminar-turbulent transition of the fluid giving you more residence time and eliminate expensive and complicated competitors shakers.

*A rig supervisor's choice  
"Roughneck Friendly Shaker"  
- simple and reliable to operate.*

- No lubrication maintenance vibrators
- Extremely low noise level less than 70dBA
- Explosion proof: CSA and FM Approved
- ATEX Certified and CE Marked
- Stainless steel covers
- Long B10 bearing lifetime
- Easy to adjust G-force
- Almost maintenance free

Our WedgeLok™ is better than the "hook style" and eliminates improper screen tension. We are the first in the industry to introduce such for quick screen panel change.



Explosion proof simple to operate starter box.

Marsh Mellow® isolator eliminates noise caused by coil spring isolator

Our Adjustable While Drilling Jacking mechanism can adjust deck angle alignment from 0° to +5°

We designed our screen using our proprietary software for high liquid throughput, maximum open area, de-blinding layout, and optimum screen life. Whether it is colloid, clay, sand, etc., our screen panel technology and decades of experience will be your guarantee that you will have an optimum mud recovery. We are an API RP 13C Compliant.

5000 BLE Balanced Linear Elliptical Motion Shaker



50B Linear Power Shaker



500B Linear Power Shaker

SERIES:	5000 LINEAR POWER SHAKER	500 LINEAR POWER SHAKER	50 LINEAR POWER SHAKER
MODEL:	BLE	B4	B4
MOTORS:	Two each 1800, 1500 or 1200 rpm exp. proof or non-exp. proof available.	Two each 1800, 1500 or 1200 rpm exp. proof or non-exp. proof available.	Two each 1800, 1500 or 1200 rpm exp. proof or non-exp. Proof available
STANDARD ELECTRICAL REQUIREMENTS	240/480 volt, 60 Hz, 3 phase ,380 volt, 50Hz, 3 phase	240/480 volt, 60Hz, 3 phase , 380 volt, 50Hz, 3 phase	240/480 volt, 60Hz, 3 phase 380 volt, 50Hz, 3 phase
BEARINGS:	Permanently sealed and lubricated.	Permanently sealed and lubricated.	Permanently sealed and lubricated.
MOTION:	Elliptical/Linear, 0.13" A (1800), 0.156" A (1500), 0.23" A (1200), 5.0 "G"	Linear, 0.13" A (1800), 0.156" A (1500), 0.23" A (1200), 5.0 "G"	Linear, 0.13" A (1800), 0.156" A (1500), 0.23" A (1200), 5.0 "G"
VGS:	Force adjustable to 7.0 "G" maximum	Force adjustable to 8.0 "G" maximum	Force adjustable to 7.0 "G" maximum
DECK ADJUSTMENT:	Adjustable 0° to 5° adjustable	Adjustable 0° to 5° adjustable	Adjustable 0° to 5° adjustable
SCREENS:	Four 42 in x 29 in pre-tensioned panels with Wedgelok™ fasteners	Three 42 in x 29 in pre-tensioned panels with Wedgelok™ fasteners	Two 42 in x 29 in pre-tensioned panels with Wedgelok™ fasteners
SCREENING AREA:	34.0 ft² (3.16 m²)	25.4 ft²(2.36 m²)	17.0 ft² (1.57 m²)
OVERALL DIMENSIONS:	146 7/8" L x 61" W x 54 5/8" H (3729 mm x 1549 mm x 1967 mm)	117" L x 73 5/8" W x 43" H (2988 mm x 1870 mm x 1091 mm)	88 1/2" L x 68 7/8" W x 42 7/8" H (2248 mm x 1747 mm x 1087 mm)
AVERAGE WEIGHT:	4600 lbs (1717 kg)	2900 lbs (1082 kg)	2300 lbs (858 kg)
WEIR HEIGHT:	38"	29"	29"

The FSI Three Minute Solution for Quick Screen Panel Change



Step 1. Remove the WedgeLok™



Step 2. Replace the screen panel



Step 3. Re-insert the WedgeLok™



500 B4X-18 Series Actual G-Force Reading



Our portable proprietary software for G-Force reading and vibration analysis.

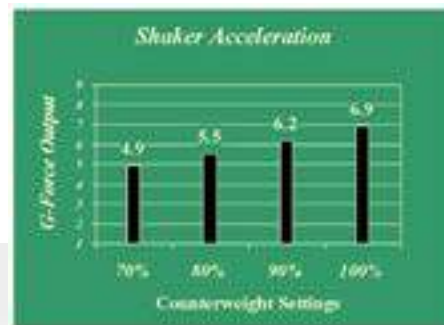

5000 BLE-18X Series Actual G-Force Reading

CASCADE SHAKER SYSTEM



<b>SERIES:</b>	500/5000 B4 LINEAR POWER CASCADE UNIT
<b>MODEL:</b>	B4
<b>MOTORS:</b>	Four each 1800, 1500, OR 1200 rpm explosion proof
<b>BEARINGS:</b>	Permanently sealed and lubricated
<b>MOTION:</b>	Linear , 0.23" A (1200), 0.156" A(1500), 0.13"A(1800), 5.0 "G"
<b>VGS:</b>	Force adjustable to 8.0 "G" maximum
<b>DECK ADJUSTMENT:</b>	0° to +5° (uphill)
<b>SCREENS:</b>	Seven each 42" x 29" pretensioned panels with <i>Wedgelok™</i> fasteners
<b>SCREENING AREA:</b>	59.4ft <sup>2</sup> (5.51m <sup>2</sup> )
<b>OVERALL DIMENSIONS:</b>	133 ¾" (2988mm) L x 73 ¾" (1870mm) W x 95 ½ "(1091mm) H
<b>AVERAGE WEIGHT:</b>	
<b>WEIR HEIGHT:</b>	83 ¼"



<b>SERIES:</b>	5000/5000 BLE LINEAR ELLIPTICAL POWER CASCADE UNIT
<b>MODEL:</b>	BLE
<b>MOTORS:</b>	Four each 1800, 1500, OR 1200 rpm explosion proof
<b>BEARINGS:</b>	Permanently sealed and lubricated
<b>MOTION:</b>	Linear , 0.23" A (1200), 0.156" A(1500), 0.13"A(1800), 5.0 "G"
<b>VGS:</b>	Force adjustable to 8.0 "G" maximum
<b>DECK ADJUSTMENT:</b>	0° to +5° (uphill)
<b>SCREENS:</b>	Eight each 42" x 29" pretensioned panels with <i>Wedgelok™</i> fasteners
<b>SCREENING AREA:</b>	68 ft <sup>2</sup>
<b>OVERALL DIMENSIONS:</b>	133 ¾" (2988mm) L x 73 ¾" (1870mm) W x 95 ½ "(1091mm) H
<b>AVERAGE WEIGHT:</b>	

500/5000 B4 Linear Power Cascade Unit



<b>SERIES:</b>	50/500 LINEAR POWER CASCADE	500/500 LINEAR POWER CASCADE
<b>MODEL:</b>	B4	B4
<b>MOTORS:</b>	Four each 1800, 1500 or 1200 rpm exp. proof or non-exp. proof available	Four each 1800, 1500 or 1200rpm exp. proof or non-exp. proof available
<b>STANDARD ELEC. REQUIREMENTS</b>	240/480 volt, 60 Hz, 3 phase 380 volt, 50 Hz, 3 phase	240/480 volt, 60 Hz, 3 phase 380 volt, 50 Hz, 3 phase
<b>BEARINGS:</b>	Permanently sealed and lubricated.	Permanently sealed and lubricated.
<b>MOTION:</b>	Linear, 0.13" A (1800), 0.156" A (1500), 0.23" A (1200), 4.5 "G"	Linear, 0.13" A(1800), 0.156" A (1500), 0.23" A (1200), 4.5 "G"
<b>VGS:</b>	Force adjustable to 9.0 "G" Maximum	Force adjustable to 9.0 "G" Maximum
<b>DECK ADJUSTMENT:</b>	Adjustable 0° to 5° uphill (lower)	Adjustable 0° to 5° uphill (lower)
<b>SCREENS:</b>	Five each 29 in x 42 in pre-tensioned panels with <i>Wedgelok™</i> fasteners	Six 29 in x 42 in pre-tensioned panels with <i>Wedgelok™</i> fasteners
<b>SCREENING AREA:</b>	42.17 ft <sup>2</sup> (3.92 m <sup>2</sup> )	50.8 ft <sup>2</sup> (4.72 m <sup>2</sup> )
<b>OVERALL DIMENSIONS:</b>	103 7/8" L x 73 5/8" W x 80 7/8" H (2638mm x 1870mm x 2053mm)	132" L x 73 5/8" W x 84" H (3353mm x 1870mm x 2134mm)
<b>AVERAGE WEIGHT:</b>	5350 lbs (2426 kg)	6220 lbs (2821 kg)
<b>WEIR HEIGHT:</b>	66 1/16" (1678 mm)	83 1/4"

50/500B Linear Power Cascade



OFFSHORE OPTIONS



Vapor Hood



Replace-A-Bed™



Our Replace-A-Bed™ retrofits shaker baskets of some competitors machine at a fraction of cost if it would take you replacing the entire machine. If your shaker basket is in bad shape which affects the performance of your equipment, switch to our balanced and simple design Replace-A-Bed™.

Model:	Series A50B Upgrade Kit	Series A500B Upgrade Kit
Screening Area:	16.9 ft <sup>2</sup> [1.57 m <sup>2</sup> ]	25.4 ft <sup>2</sup> [2.36m <sup>2</sup> ]
Screens :	two 29" x 42" pretensioned panels	three 29" x 42" pretensioned panels
Dimensions:	70" L x 68 7/8" W x 20"H [1778mm x 1747mm x 508mm]	100" L x 73 5/8" W x 24" H [2540mm x 1870mm x 610mm]
Motors:	two permanently sealed & lubricated vibrators 1200, 1500 & 1800 RPM available	two permanently sealed & lubricated vibrators 1200, 1500 & 1800 RPM available
Standard Electrical Requirements:	240/480 volt, 60 Hertz, 3 phase, 380 volt, 50 Hz, 3 phase	240/480 volt, 60 Hertz, 3 phase, 380 volt, 50 Hz, 3 phase

Flow Line Dividers



Our Flow dividers receive the flow from the flow line and distribute it equally between the number of shakers on the mud pits. These Flow dividers have manual (air valves available) to control the flows and also contain a separate cement bypass valve to bypass the shakers.

PART NO.	DESCRIPTION
EFSI3WFD	Flow divider to feed three (3) shakers including cement bypass valve.
EFSI4FLDB	Flow divider to feed four (4) shakers including cement bypass valve.
EFSI5FLDB	Flow divider to feed five (5) shakers including cement bypass valve.

G-Force Meter/Vibration Analyzer



The performance of your equipment is very vital in any rig operation. Now you can test and gather information easily with this instrument. It is easy to set up, install probes and very simple to use. Test results and analysis can be printed at your convenience. This package includes:

1. mini-laptop
2. vibration analyzer software
3. NI USB-9234 Module
4. PCB Biaxial Accelerometer
5. PCB 4-Conductor BNC Cable

FSI's proprietary software for vibration analysis and G-force measurement is a proven instrument in the field. Its portable and lightweight parts make it ideal for any rig personnel to carry and bring it onsite.

Fluid Systems advances the concept of shaker design with its innovative convertible features. FSI's dual-function design offers versatility while achieving optimum performance - even in the most challenging applications. This can easily be set to operate with linear motion or just as easily with balanced elliptical motion for optimum separation and consistently high throughput .

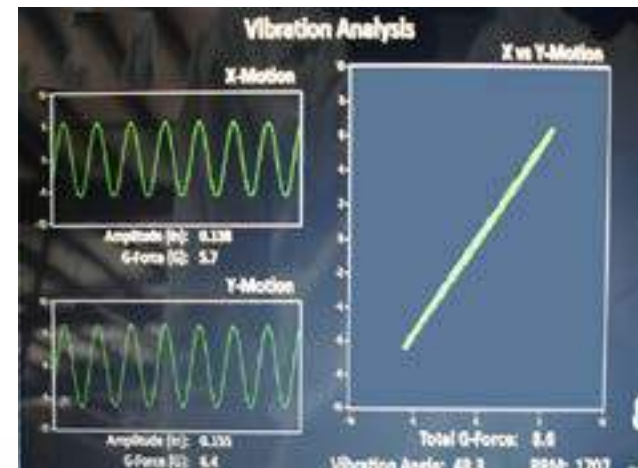

Typical Linear Motion

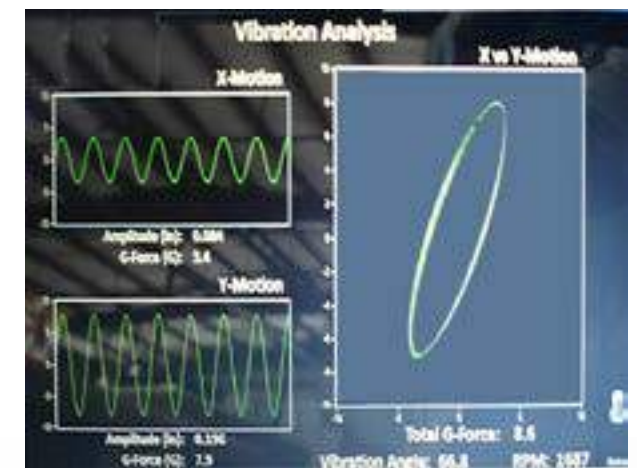

Typical Elliptical Motion

ONE-LIFT SKID SYSTEM



FEATURES:

This three-piece unit combined into one integral assembly can be lifted and mounted as single unit for economy of time and motion. This reduces assembly time, shaker alignment and positioning at the rig site. Its flow distribution can be controlled by slide gates.

Overall dimensions:	250 1/4 " x 154 3/4" x 137" 6356mm x 3931mm x 3479mm
Weight:	21,500lbs[9773 kg] approx.
Weir Height:	37 15/16"

MUD CLEANERS (CONDITIONERS)

Mud cleaner is a combination of hydrocyclones mounted above a shale shaker. The primary use of the mud cleaner has always been the removal of drilled solids larger than barite. Its secondary purpose is to remove drilled solids from unweighted drilling fluids. With many models from which to choose, FSI offers a mud cleaner to meet the requirements of most all

NEW DESILTER CONCEPT!!

FEATURES:

All FSI mud cleaners offer a number of features that ensure both high performance and long life:

- High volume desilter and desander hydrocyclones.
- Consistently high "G" forces generated.
- Permanently sealed vibrators, which eliminate the need for a lubrication system.
- Easy installation (3 minutes or less) of pre-tensioned screen panels, each independent of the other.
- Low operating noise(80dB).
- Small footprint for efficient use of rig real estate.
- Maintenance requirements limited to inspection of various assemblies, inflation of air spring assemblies, and torque-checking of vibrator motor bolts.



5000 The eLIMINATOR™



the HP eLIMINATOR™

Parts of Mud Cleaner

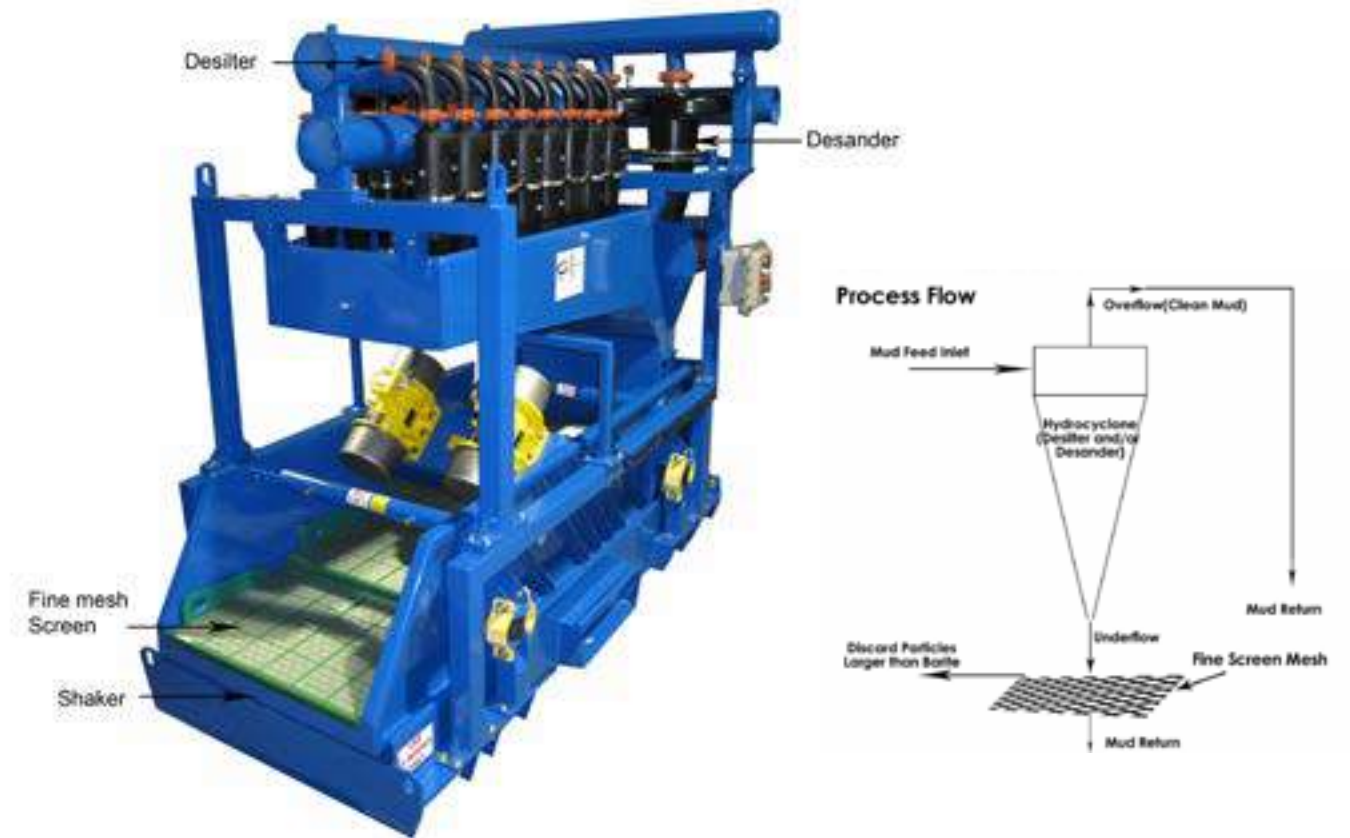

Series 5000 BDHC Mud Cleaner

SERIES:	5000 Mud Cleaner	500 Mud Cleaner	5000 The Eliminator™
MODEL:	B4 DHC	B4NP102DHC	B4
MOTORS:	Two each 1800, 1500 or 1200rpm exp. proof or non-exp. proof available	Two each 1800, 1500 or 1200rpm exp. proof or non-exp. proof available	Two each 1800, 1500 or 1200rpm exp. proof or non-exp. proof available
STANDARD ELECTRICAL REQUIREMENTS	240/480 volt, 60Hz, 3 phase 380 volt, 50Hz, 3 phase	240/480 volt, 60Hz, 3 phase 380 volt, 50Hz, 3 phase	240/480 volt, 60Hz, 3 phase 380 volt, 50Hz, 3 phase
BEARINGS:	Permanently sealed and lubricated.	Permanently sealed and lubricated.	Permanently sealed and lubricated.
MOTION:	Linear, 0.13" A(1800), 0.156" A (1500), 0.23" A(1200), 4.5 "G"	Linear, 0.13" A(1800), 0.156" A (1500), 0.23" A(1200), 4.5 "G"	Linear, 0.13" A(1800), 0.156" A (1500), 0.23" A(1200), 4.5 "G"
VGS:	Force adjustable to 8.0 "G" maximum	Force adjustable to 8.0 "G" maximum	Force adjustable to 7.0 "G" maximum
DECK ADJUSTMENT:	Adjustable 0° to 5° uphill	Adjustable 0° to 5° uphill	Adjustable 0° to 5° uphill
SCREENS:	Four each 29" x 42" pre-tensioned panels with Wedgelok™ fasteners.	Three each 29" x 42" pre-tensioned panels with Wedgelok™ fasteners.	Four each 29" x 42" pre-tensioned panels with Wedgelok™ fasteners.
SCREENING AREA:	34 ft²(3.16 m²)	25.4 ft²(2.36 m²)	34 ft²(3.16 m²)
OVERALL DIMENSIONS:	131 1/2" L x 65 1/2" W x 105 5/8" H 3340mm x 1664mm x 2681mm	109 7/8" L x 73 3/4" W x 90" H 2789mm x 1873mm x 2287mm	131 1/8" L x 67 5/8"W x 82 1/2"H 3331mm x 1718mm x 2096mm
APPROX. WEIGHT:	6635 lbs (3016 kg)	4050 lbs (1841 kg)	5550 lbs (2523 kg)
CONES:	Up to sixteen 4" desilter cones (100 GPM each) Up to three 10" desander cones (500 GPM each)	Up to ten 4" desilter cones (100 GPM each) Up to two 10" desander cones (500 GPM each)	Up to Four 8 in cone (desander-desilter in one) 350 gpm each - 1400 GPM Total

HYDROCYCLONES

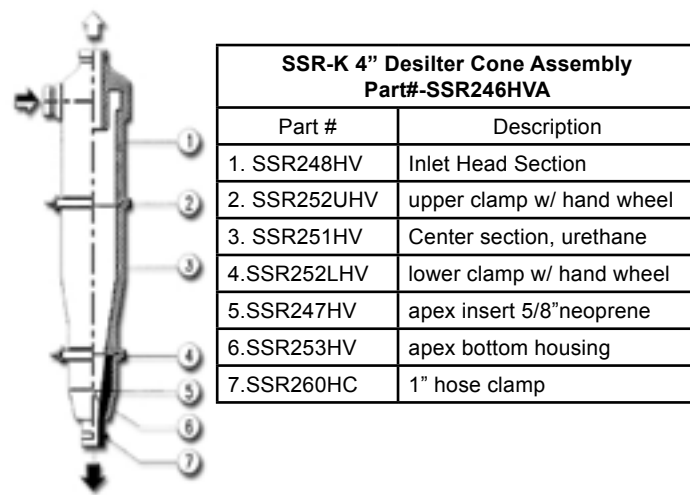

SSR-K 4" Desilter Cone Assembly Part#-SSR246HVA	
Part #	Description
1. SSR248HV	Inlet Head Section
2. SSR252UHV	upper clamp w/ hand wheel
3. SSR251HV	Center section, urethane
4. SSR252LHV	lower clamp w/ hand wheel
5. SSR247HV	apex insert 5/8" neoprene
6. SSR253HV	apex bottom housing
7. SSR260HC	1" hose clamp

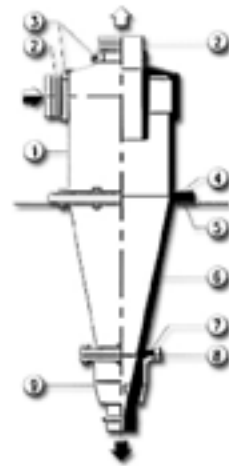

10" Desander Cone Assembly Part#-DSR234A	
Part #	Description
1. DSR233	Cone Feed Section
2. DSR233A	overflow fittings
3. DSR233B	overflow clamps
4. DSR236RP	upper retainer plate
5. DSR236BP	upper backing plate
6. DSR232	center cone body
7. DSR235BP	lower backing plate
8. DSR235RP	lower retainer plate
9. DSR168A	adjustable apex assembly

FSI hydrocyclones are designed to replace most standard desilting or desanding equipment. Manufactured from high-resistant polyurethane, FSI cones feature long, reliable life. Each hydrocyclone represents a product of advanced design. With interdependence of its inlet, vortex and apex orifices, the separation of fine, light and coarse particles is achieved with

CONE	CAPACITY@75ft of head	D50 Cut Point(microns)
4"	100 GPM	20-40
10"	500 GPM	60-80

DESANDERS



DESILTERS



SERIES:	DSR-F	SSR-F	SSR Desilter S
No. of cones available	1 to 4 per header	1 to 16 per header	1 to 20 per header
Inlet Size:	Depending on no. of cones	Depending on no. of cones	Depending on no. of cones
Outlet Size:	Depending on no. of cones	Depending on no. of cones	Depending on no. of cones
Overall dimensions:	52" x 32" x 76"	Depending on no. of cones	56" x 35" x 65"
Cone Capacities:	500 GPM (1892.70 lpm) per cone	100 GPM(378.5 lpm) @ 40psi (2.8kg/sq.cm)	60 GPM (227 lpm) @ 40psi (2.8kg/sq.cm)
Cone construction:	High durameter cast polyurethane	High durameter cast polyurethane	High durameter cast polyurethane
Weight:	550 lbs. ( 249 kg)	675 lbs (306kg)	975 lbs. (442 kg)

ROUND VACUUM DEGASSER



FEATURES:

- 5 hp or 7.5hp motor 60 Hz 480 volt 3 phase with starter and fan guard.
- up to 29" Hg performance for viscous fluids.
- epoxy coated internal surface resist corrosion.
- fail-safe overflow valve.
- low maintenance float assembly.
- easy access to baffles and float switch.
- compact design for easy placement.
- skid, self-contained unit.
- minimum moving parts for reliable operation.
- 4000 lbs. average dry weight.

FSI PART No. E100VDG

Flow rate:	1200 GPM [4542 lpm]
Leaf Area:	14,528in <sup>2</sup> [369011 mm <sup>2</sup> ]
Static Weight:	3900 lbs [1769 kg]

PRINCIPLE OF OPERATION

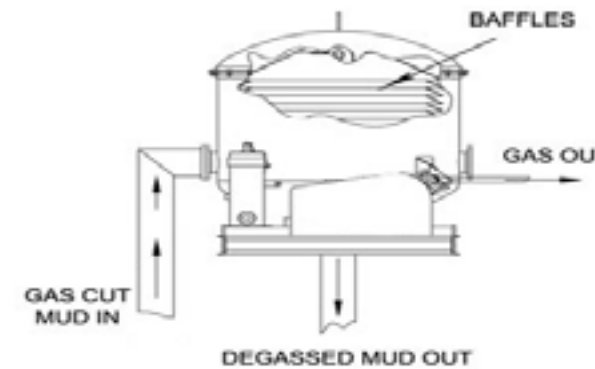

ATMOSPHERIC DEGASSER



Atmospheric Degassers remove retained gas from drilling muds. The DSDG atmospheric degasser degasses mud by accelerating fluid through a submerged pump impeller and impinging the fluid on stationary baffles to maximize surface area and thus enable gasses to escape to the atmosphere. As with all processing equipment the process rate is dependent upon solids content and fluid viscosity. Processing rates are therefore dependent on mud properties.

FSI PART No. E1200VDG

Flow rate:	1000 GPM [ lpm]
Leaf Area:	
Static Weight:	3900 lbs [1769 kg]

Our vacuum degasser operates on a "thin strata" principle. The drill mud enters the tank, forces it to flow and distributed to a layer of internal baffle plates engineered to allow the liquid inside the vacuum degasser to flow as thin film and is exposed to the vacuum within the vessel. This layer of mud allows the gas to escape or break out of the mud. The vacuum pump releases the gas and discharge it to the disposal line. Mud exits the vessel under the action of the venturi and is returned to the mud system.

FSI vacuum degasser operates in three functions – mud circulation, vacuum creation and gas removal. The venturi nozzle at the discharge piping creates vacuum within the vessel and circulates mud by drawing entrained bubbles in the mud into the vessel. The vacuum pump runs continuously removing gas from the vessel discharging it to the rig's flare or environmental control system.

It is a compact, skid-mounted and self-contained unit designed to separate and vent trip gas and heavily gas cut mud. Its series of baffles are made of corrugated fiberglass infused with epoxy for long life with access plate for easy

MUD GAS SEPARATORS

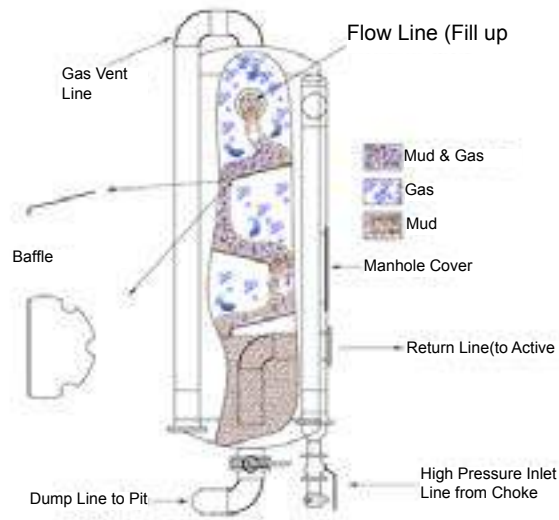

Process Flow for Mud Gas Separator

Compact mud gas separators, together with the choke, are designed to effectively vent “free” gas to a safe distance from the rig and return the mud to the mud pits. Gas entrenched in the mud can be removed by the mud gas separator. Fold-down models, designed for easy land-rig transport or offshore use, feature a small footprint. Several sizes are available, depending on the volume to be processed. Most “Land” mud gas separators have telescopic frame to vary its height to meet the desired altitude for the flow line connection.



Lay-down position for easy transport



Telescopic Frame



Offshore Model

Specifications:

MGS Model	4ft x 12ft	4ft x 18ft	4ft x 30ft	6ft x 22ft
Fluid Capacity	1000 gpm	1500 gpm	1500 gpm	1750 gpm
Gas Capacity	12 MMscf/d	17.5 MMscf/d	25 MMscf/d	83 MMscf/d
Vessel Diameter	48" [1219mm]	48" [1219mm]	48" [1219mm]	72" [1829 mm]
Vessel Height	12ft [3657mm]	18ft [5486mm]	30ft [9144mm]	22ft [6706mm]
FSI Part No.	EFSIMGS4X12-OS-ASME-SS	EFSIMGS4X18-OS-ASME-SS	EFSIMGS4X30-OS-ASME-SS	EFSIMGS6X22-OS-ASME-SS
Working Temperature	32° - 212° F [0° -100° C]	32° - 212° F [0° -100° C]	32° - 212° F [0° -100° C]	32° - 212° F [0° -100° C]
H2S	Yes	Yes	Yes	Yes
Nace	MR-01-75	MR-01-75	MR-01-75	MR-01-75
ASME Boiler and Pressure Vessel Code	Section VIII, Div I, Sect IX Lethal Service	Section VIII, Div I, Sect IX	Section VIII, Div I, Sect IX	Section VIII, Div I, Sect IX
Working Pressure	125 PSI [8.6 bar]	125 PSI [8.6 bar]	125 PSI [8.6 bar]	125 PSI [8.6 bar]
Approximate weight				24,000 lbs [10,886 Kg]

CENTRIFUGAL PUMPS



FSI centrifugal pumps feature highly reinforced housing and heavy-duty impellers for long, trouble-free life. These proven pumps are designed to be interchangeable with popular brands, ensuring ease of maintenance and manageable parts inventories. It is designed to charge desanders, desilters, mud mixing operations and fresh water transfer.

Pump Selection:

Careful selection of centrifugal pump will result in a unit that will provide long lasting and dependable service. The following information is required.

1. Type of operation to be performed
2. Amount of head and volume required for the operation.
3. The type of driver desired (electric or engine)
4. Specific gravity or weight of fluid to be handled.
5. Total head loss due to friction plus the total net lift above the mud level suction is taken from.
6. Temperature, corrosiveness and abrasiveness of the fluid.

Our experience , engineering capability and the performance of pumps will guide you for correct impeller size, required horsepower and NPSH(Net Positive Suction Head).



Standard Centrifugal Pump Package	
3x2x13	10hp up to 60 hp
4x3x13	10hp up to 75hp
5x6x14	50hp up to 100hp
6x5x11	50hp up to 100hp
6x8x11	60hp up to 100hp
6x8x14	60hp up to 250 hp
Other combinations are also available	

MUD AGITATORS

FSI offers a choice of heavy-duty agitators in 7.5, 10, 15, 20, and 25 hp models. Available in 60 Hz, 480 volt (50 Hz 380V also available), 3 phase, UL Class 1 Div.1, Group D, Class II E, F and G explosion proof "C" faced motor; complete with Helical-Bevel gear box, shaft, impeller and stabilizer. Average TOR is 60 seconds. Noise level: -75dBA . Customers can choose between vertical or horizontal installations. Fluid Systems Inc. uses an impeller to mix and suspend the solids using both axial and radial flows, and by utilizing low shear mixers to suspend and mix mud additives particle size degradation and polymer shear. Unlike centrifugal pumps or mud guns. It is relatively low shear and low energy device, so it's easy to operate and inexpensive to maintain. This will ensure that mud additives are homogeneously mixed to prevent dead spots. Agitators will keep the active mud system flowing even when the pumps are disengaged and keep the weighting agents in suspension.

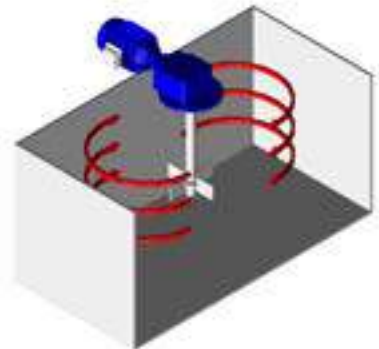

Radial Flow

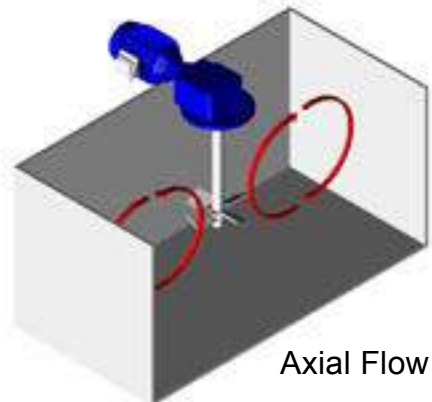

Axial Flow

BENEFITS OF MUD AGITATOR:

- Increase performance of solids removal equipment.
- Maintain a uniform mud density.
- Prevents solids settling , taking up valuable tank displacement.
- High shear mixing, aids chemical and solids addition.

MUD GUNS

For many years, mud guns applying venturi principle were used as the sole means of agitation . These devices usually carry mud from a downstream compartment and spray it into an upstream compartment to keep solids suspended. Fluid Systems' nozzles are made of special high wear resistant urethane which lowers repair cost by increasing nozzle life 10-20 times over mild steel, increasing mud mixing pump life by preventing large increases in mixing gun volume which causes cavitation and eliminating sharp reducers. Tank depth or dimension "y" and volume should be specified for the proper mud gun quantities. Mud guns come in 2" (FSI Part No. FSI2STMG) and 3" (FSI Part No. FSI3STMG)



Standard MUD HOPPERS



	6" Hopper		4" Hopper	
Choke Nipple Bore	2" [51mm]		3/4" [19mm]	
Pressure:	40-65psi [2.812-4.569kg/cm <sup>2</sup> ]		40-65psi 2.812-4.569kg/cm <sup>2</sup>	
	MUD	BULK SOLIDS	MUD	BULK SOLIDS

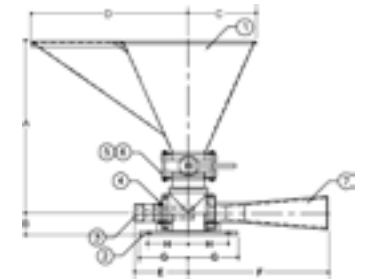
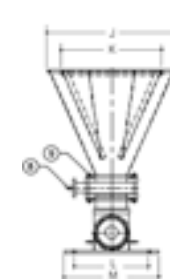
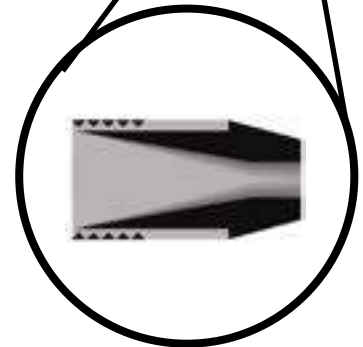
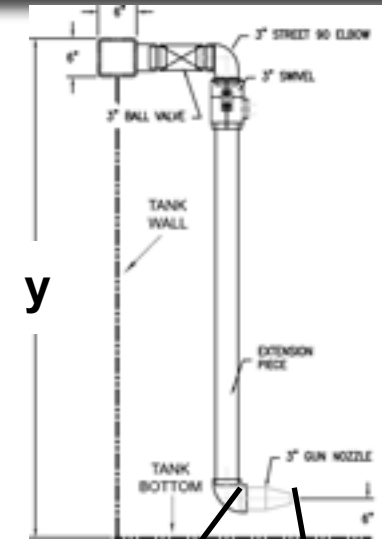

6 inch Hopper

A	B	C	D	E	F	G	H	J	K	L	M
36.5"	4.5	14	31.25	27.5	11.25	10	8	28	21	16	20

4 inch Hopper

A	B	C	D	E	F	G	H	J	K	L	M
36.5"	4.5	14	31.25	16.5	9.5	10	8	28	21	16	20

\* Where grating will be installed over piping add "T" behind part number. "A" dimension will be increased by 6 inches.

MUD ROOM



Bulk Silo

The Fluid Systems Bulk Silos are used to transfer and store bulk barite and bulk cement when transferred from a marine supply vessel. During the conveying process of material transfer, the vented dust is routed through a connecting pipe to a Dust Recovery Tank which is fitted with an Air Cyclone that uses special features developed by Vortex Ventures to separate the air and suspended solid particles.

The exhausted air is discharged from the Air Cyclone with a particle size of less than 12 microns. To further reduce solid particle release to the atmosphere filter sock may be used on the vent line from the Air Cyclone. Solid particles with a size greater than 12 microns are directed downward out of the Air Cyclone into the Dust Recovery Tank, ensuring minimal product loss.



Our Dust Recovery Tanks are fitted with an Air Cyclone that uses special features developed by Vortex Ventures™ to separate the air and suspended solid particles. The exhausted air is discharged from the Air Cyclone with a particle size of less than 12 microns. To further reduce the solid particles released to the atmosphere, a filter sock can be used on the vent line from the Air Cyclone.

With Fluid Systems Product Recovery Tanks, solid particles with a size greater than 12 microns are directed downward out of the Air Cyclone into the tank, ensuring minimal product loss.

**Benefits:**

- Reduce product loss during mixing**
- Eliminate solid particle release to the atmosphere**
- Transfer recovered product back to the storage silo**

Our Dust-Free Speed Mixing System delivers ultimate blending performance together with optimal dust control. The Dual Suction Lobestar® Shear/Mixer prevents dust from being generated during the mixing of drilling fluid products in the mudroom while the dust containment assembly provides a hermetic seal between the Surge Tank and the Lobestar Shear/Mixer. As such, bulk barite and bulk bentonite can be rapidly delivered and mixed at a regulated rate in a dust-free environment.

**Benefits:**

- Reduced mixing time**
- Less material required**
- Rapid and stable rheological properties**
- On-site oil-based drilling fluid preparation**
- Free of fisheyes and microgels**



Dust Free Mixing System



Dust Recovery Systems for Bulk Silo

The Fluid Systems Bulk Bag Handling System provides a simple and effective method to completely eliminate dust and remove the health risk associated with drilling fluid additive in a confined enclosure. Our Bulk Bag Handling System uses the vacuum generated by the Mixing Educator™ to promote a uniform and uninterrupted material flow. The vacuum also causes empty bags to collapse dust-free before disconnecting, eliminating dust emission during manual flattening of the empty bags. The Bulk Bag Handling System incorporates a Fluid Systems Shear/Mixer with a bulk-bag frame and hopper. It reduces space, handling and the elimination of wooden pallets and paper bags.

**Benefits:**

- Dust Containment**
- Increased Mixing Rate**
- Improved Product Delivery**
- Rapid Hydration**
- Custom Designs**



Big Bag Handling

CAUSTIC SODA MIXERS

Designed to handle the most demanding substances, the Fluid Systems Automatic Caustic Soda Mixer is a mixing device for safely mixing and dispensing strong and aggressive, hazardous chemicals, such as caustic soda, soda ash and drilling fluid emulsifiers directly to the active fluid system.

The built in impeller generates a turbulent swirl that provides rapid volume turnover and mixing for chemical dissolution and uniform blending.

In addition, the Fluid Systems Automatic Caustic Soda Mixer is ideally suited to use with the Fluid Systems Shear/Mixer. A hose or pipe can be connected between the tank outlet and a suction connection located on the side of the eductor body.

Caustic soda mixer is designed to handle and safely mix strong and aggressive substances. Uniform blending and homogeneity will be achieved with the mixing action of its impeller.

Capacity : 10 bbl  
 Dimensions: 54"L x 42 9/16"W x 47 3/8"H  
 [1371.6mm L x 1080mm W x 47 3/8 1202.9mm]

Manual or Electric Operated Available



PRESSURE WASHING MACHINES



- Explosion Proof
- 3000 or 5000 psi Hot/Cold 480 Volt Electric Pressure Washer
- Class 1, Division 1 Motor
- 4 Point Lifting System with Pull Test Certification
- Double Barrel Wand
- High Pressure Hose
- Tool Box
- Fork Slots
- Offshore Certified

FLUID SYSTEMS VIBRATOR MOTORS



FEATURES:

- Lubricated for life
- Long B10 bearing lifetime
- Maintenance free for years of service
- Stainless steel end covers
- Long B10 bearing lifetime
- Easy to adjust G-force
- Explosion proof; CSA and FM approved
- Extremely quiet less than 70dBA
- ATEX Certified and CE Marked

The Fluid Systems vibrator motor can sustain higher starting torque and lower operating temperature than competing models. Its watertight stainless steel eccentric weight covers allow for wash downs in corrosive environments. With large diameter silicon O-ring to provide sealing, a stable and secure mounting with its two rail base design, and easily adjusted counterweights, makes this a top of the line OEM and replacement vibrator motor.

SHEAR MIXERS



Shear Mixer

With the Fluid Systems Shear/Mixer Bag Slitter, workers benefit from a cleaner and healthier work environment. The product bag is placed on the roller table conveyor then tilted over into the hopper and pierced by the bag slitter. The bag content is then drawn through the Bag Slitter suction slots into the suction without creating dust.

When emptying the bag content through the Bag Slitter and into the suction, the bag conforms to the internal contour of the hopper causing a soft seal between the bag and the wall of the hopper. This prevents dust from escaping from the hopper while dosing in chemicals and other powdered drilling fluid products.

CUTTINGS DRIERS

VERTICAL CUTTINGS DRIER SYSTEMS



3D Double Deck Drier



5000 BLE CD LP



500 B4 CD LP



5000 BLE CD

Technical Specifications for Cutting Driers

LINEAR POWER CUTTINGS DRIERS			
Series:	29126	5000	500
Model:	3D	BLE CD and LP	B4 CD and LP
Motors:	Two each 1800 rpm exp. proof or non-exp. proof available	Two each 1800 rpm exp. proof or non-exp. proof available	Two each 1800 rpm exp. proof or non-exp. proof available
Bearings:	Permanently sealed and lubricated	Permanently sealed and lubricated	Permanently sealed and lubricated
Motion:	Linear, 0.13" A, 4.5 "G", 20Hz	Linear, 0.13" A, 4.5 "G", 20Hz	Linear, 0.13" A, 4.5 "G", 20Hz
VGS:	Force adjustable to 10.0 "G" maximum	Force adjustable to 7.0 "G" maximum	Force adjustable to 7.0 "G" maximum
Screens:	Six each 29" x 42" pre-tensioned panels with Wedgelok™ fasteners	Four each 29" x 42" pre-tensioned panels with Wedgelok™ fasteners	Three each 29" x 42" pre-tensioned panels with Wedgelok™ fasteners
Screening Area:	50.7 sq.ft. [4.7 sq.m]	34 sq.ft. [3.16 sq.m]	25.3 sq.ft. [2.35 sq.m]
Overall Dimensions:	140" L x 63 9/16" W x 54 1/4" H	Std CD: 129 1/2" L x 67 5/8" W x 52" H CD LP: 129 1/2" L x 67 5/8" W x	Std CD:

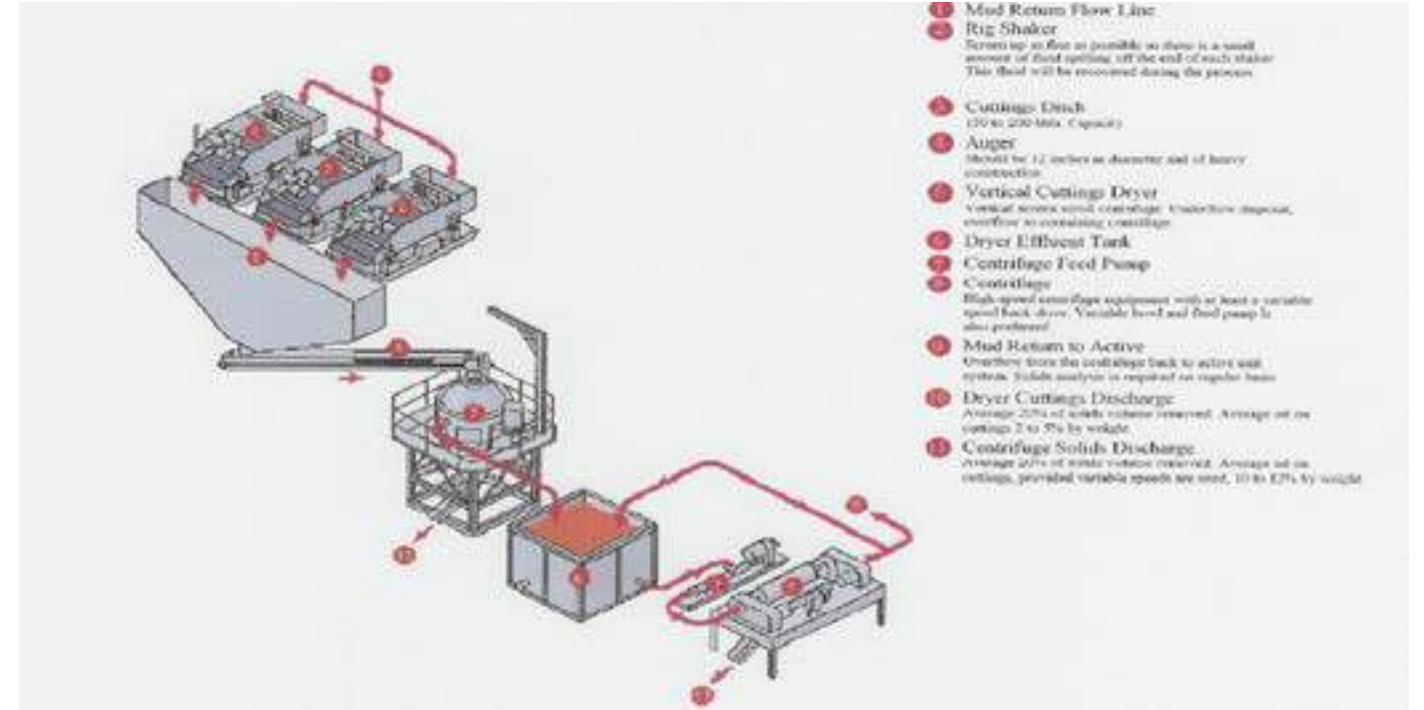

THE DEHYDRATOR VERTICAL DRIER

Fluid Systems Dehydrator vertical centrifuge can recover up to 95% of drilling fluids from your discarded cuttings. The substantial reduction in liquid/oil adhesion yields retort analysis of Dehydrator discards ranging from 6% to as low as 1% oil by weight.



MODEL	CAPACITY	DIMENSIONS	Weight	Drive Motor
DH1	40 TO 60 TPH	106" [2235mm] L x 88" [2235mm] W x 72" [1829mm] H	9600 lbs [4355 kg]	75 HP
DH3	25 TO 40 TPH	88" [2235mm] L x 64" [1626mm] W x 48" [1219mm] H	4200 lbs [1905 kg]	30 HP
DH4	40 to 60 TPH	99" [2515mm] L x 88" [2235mm] W x 68" [1727mm] H	7700 lbs [3493 kg]	75 HP

SCREW CONVEYORS (AUGERS)

FSI offers a choice of standard screw conveyors (all sizes available) to transport cuttings for disposal or treatment on your location. Each screw conveyor is made up of 6 feet or 12 feet lengths that can be bolted together and sized to fit your application. We manufacture screw conveyors out of carbon steel, abrasion resistant steel, stainless steel or other alloys to suit any specific requirements. Available diameters from 6" to 24". Explosion proof electrical design.



In determining the horsepower requirement to overcome friction and convey the material at specified rate important criteria should be considered such as total length of conveyor, properties of material to be handled, size of lumps, capacity required, flight type, screw diameter, flowability, material abrasiveness, handling temperature, corrosiveness and required duty of construction like overload factor, drive efficiency, flight factor etc. Our experienced engineers had already established design factors for optimum screw conveyor performance.

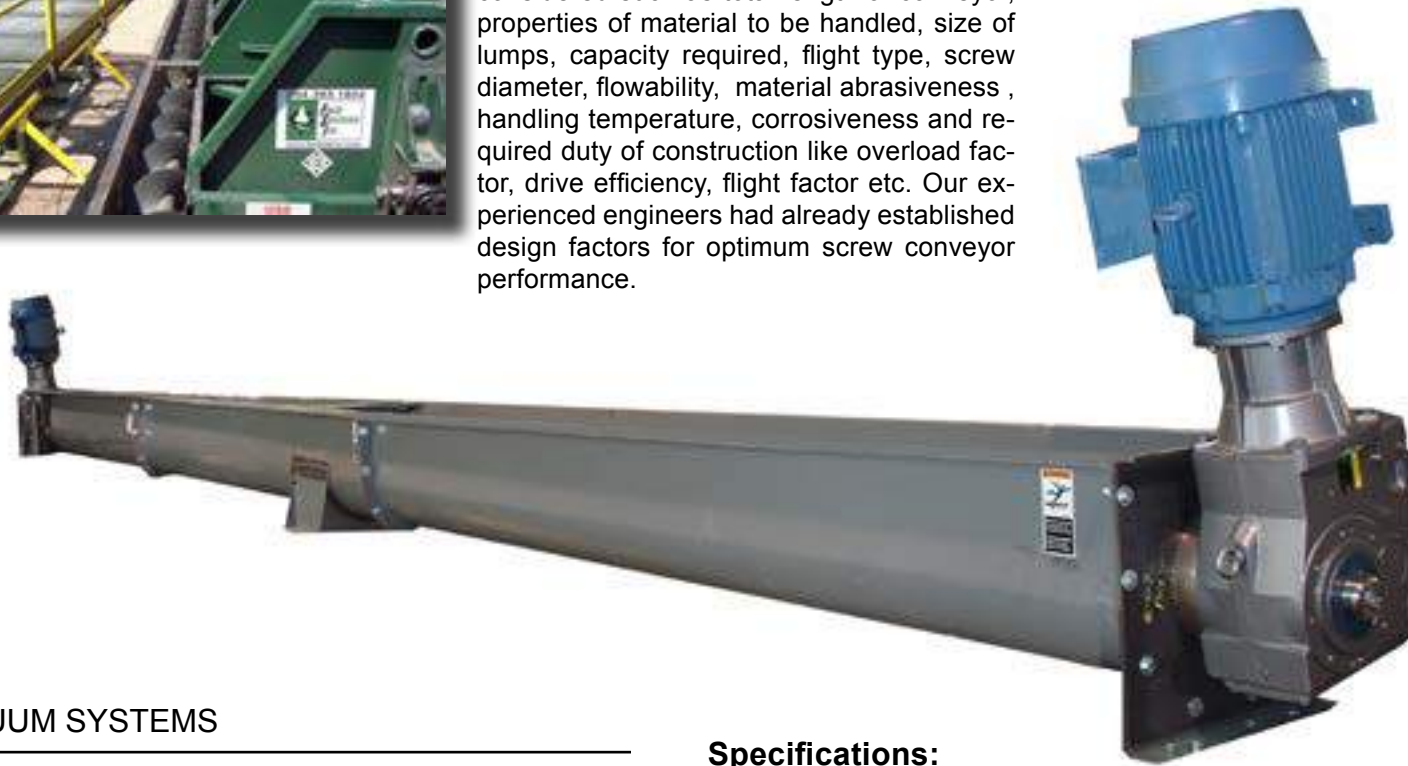

VACUUM SYSTEMS

Specifications:

This Vacuum is Capable of Reverse Flow  
 The Approximate Overall Skid Dimensions are 6' x 12' x 9'  
 A 15 (+-) bbl Collection Tank is Mounted on the Skid  
 Challenger 607 Heavy Duty Vacuum Pump Capable of 27 INHG and 29 psi  
 Driven by a 30 hp (up to 150 HP Available) 1750 rpm Class 1, Division 1 Motor  
 Combination Vacuum and Pressure Gauge Comes Standard  
 Class 1, Division 2 Electrical System  
 Separate Remote Start/Stop Switch is Standard  
 A Pad Eye Lift System is Located in Each Corner of the Overhead Rack and is Pull Tested with Certificate  
 The Unit is Equipped with a Tool Box to be Mounted on the Skid for Spare Parts  
 The Unit Comes Primed and Painted with a Two Coat Epoxy System



SHAKER CUTTINGS DRIER SYSTEMS



Operating Mode



Transport Mode

Eliminate costly installations by using these "plug and play" shaker drier systems - all in one systems makes installations very easy and inexpensive.



The FLUID SYSTEMS, INC. cuttings drier shaker systems are manufactured to include all appurtenances (access platforms, stairways, pipe supports, walkways and service platforms, light brackets, etc...). These systems have become the standard when operating waste management systems worldwide. To install a system all one has to do is place it under the rig shakers, unfold the walkways, size shale slides to fit, place screw conveyor or cuttings tank in front of shakers, plug system into rig power or generator, check rotation on equipment and drill away.

CUSTOM TRAILER DEWATERING SYSTEMS



Dewatering Trailer with liquid polymer system



The Customized closed loop/dewatering mobile units are designed to process waste mud from the rig tanks or shaker skid liquid tank to produce clean water which is suitable for re-use on site and solids which are more easily handled for disposal.

The units are contained inside weather proof enclosures specifically designed for work in harsh and cold oilfield environments. The weather proof enclosures are designed for quick disassembly and re-assembly in case the centrifuge or other equipment needs to be removed or replaced. Sides are incorporated into the design for durability and protection each time the system is rigged up or down. Heavy duty canvas tarps are stretched between the openings and attached to light weight metal frame.

The unitized construction includes all requested storage and mixing tanks as well as required pumps. One feed tank that receives mud from either the cuttings dryer shaker skid or the rig tanks. The material in the tank is then transferred to the centrifuge. There is a platform and a ladder with an OSHA back guard for easy access in the rear of the trailer system. The 3 x 4 centrifugal pump is standard oilfield design made to withstand rigorous applications. A high- low level alarm system is built into the feed tank to closely monitor the operations.



DRY POLYMER PREP SYSTEM

DEWATERING SYSTEMS

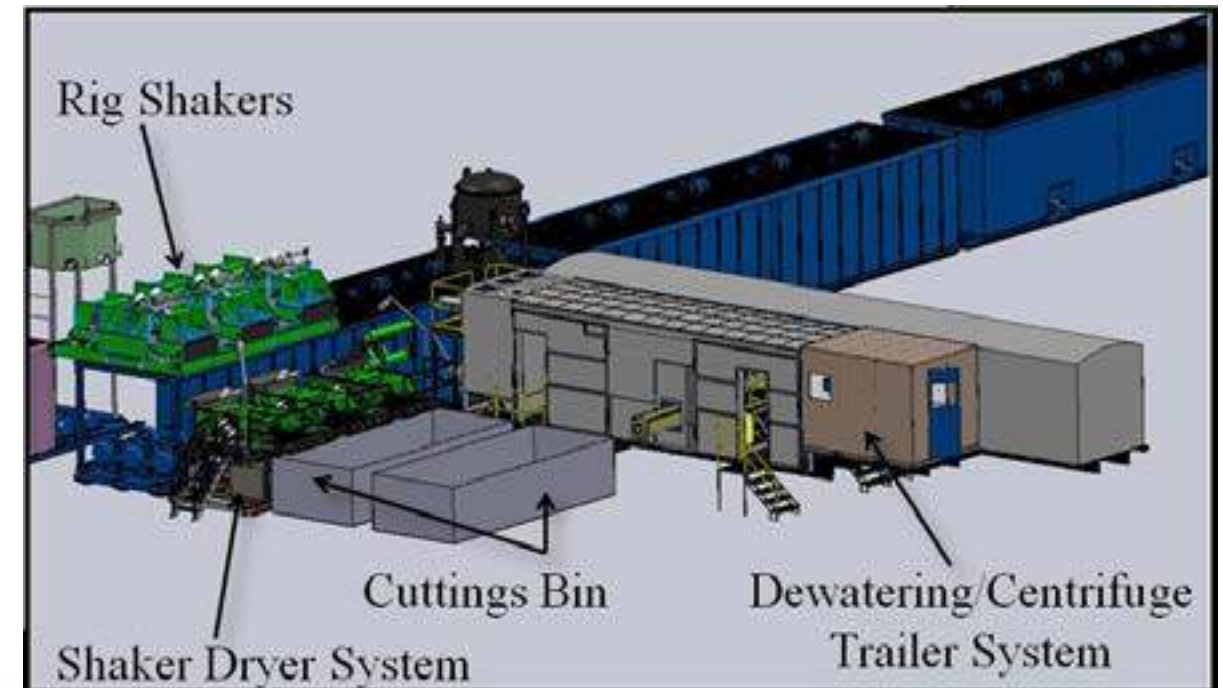

CENTRIFUGES



These high performance centrifuges are able to work with a centrifugal acceleration up to 3500 G Force. It's entire rotating assembly is mounted in a "Split Case" operating in a solid "big bowl" designed for maximum separation of solids/liquid in two phases.

PRINCIPLE OF OPERATION

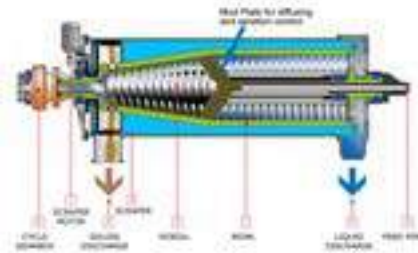

Centrifuge Model	FORCE 20 (14in x 56in)	FORCE 40 (19in x 80in)
Hydraulic capacity	265 gpm [1000 LPM]	440 gpm [1665 LPM]
Total Length	138.5" [3509mm]	180.43" [4583mm]
Total Width	36" [910mm]	45.28" [1150mm]
Total Height	39" [990mm]	54" [1371mm]
Housing	Carbon Steel (split case)	Carbon Steel (split case)
Solids Output	5.5 tons/Hr [5.0 Tonnes/Hr]	12 tons/Hr [10.9 Tonnes/Hr]
Screw flight coated from both side with tungsten carbide		
Bowl Diameter	14" [355mm]	19" [483mm]
Bowl length	56" [1422mm]	80" [2013mm]
Bowl max. speed	4000 rpm	3650rpm
Torque (in-lbs)	43,000	53,100
Differential speed	2 to 67 rpm	2 to 40 rpm
Bowl powered by belt transmission and electric motors		
Electric motors	Main Drive: 50HP [37 Kw] Back Drive: 20HP [15 Kw]	Main Drive: 125HP [93 Kw] Back Drive: 20HP [15 Kw]
VFD starter controls the main drive/ back drive/ and feed pump		
Vibration isolators under decanter frame		
Noise level	80dB	80dB
Weight	6000lbs [2722 Kg]	10500lbs [4783 Kg]
Voltage	480 V 60Hz 3 Phase/50Hz available	480 V 60Hz 3 Phase/50Hz available
Vibration control		
Oilfield Skid		

COMPLETE MUD SYSTEMS

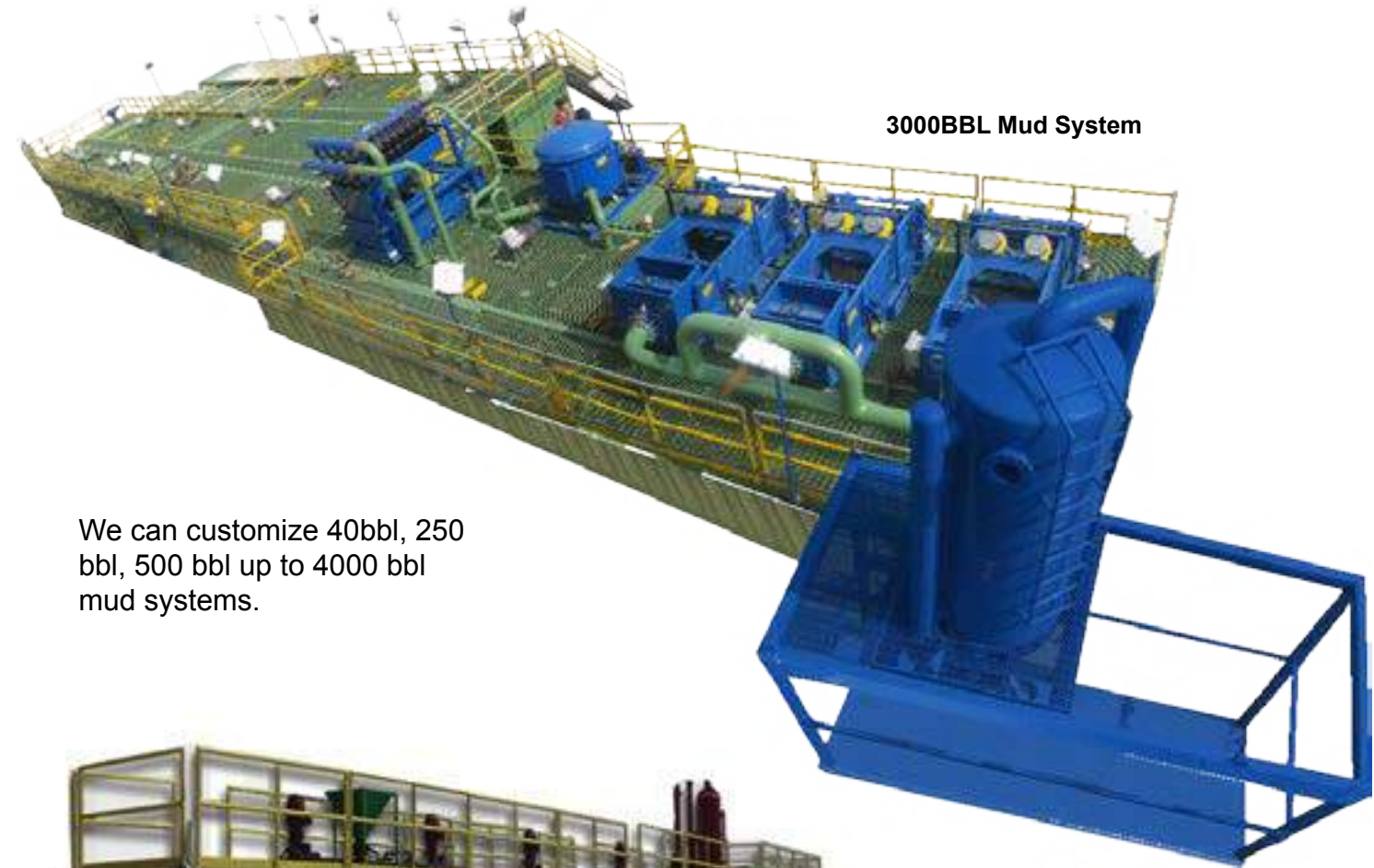

3000BBL Mud System

We can customize 40bbl, 250 bbl, 500 bbl up to 4000 bbl mud systems.



250BBL Mud System for Workover Drilling



40BBL Mud Systems for Methane Drilling or small projects

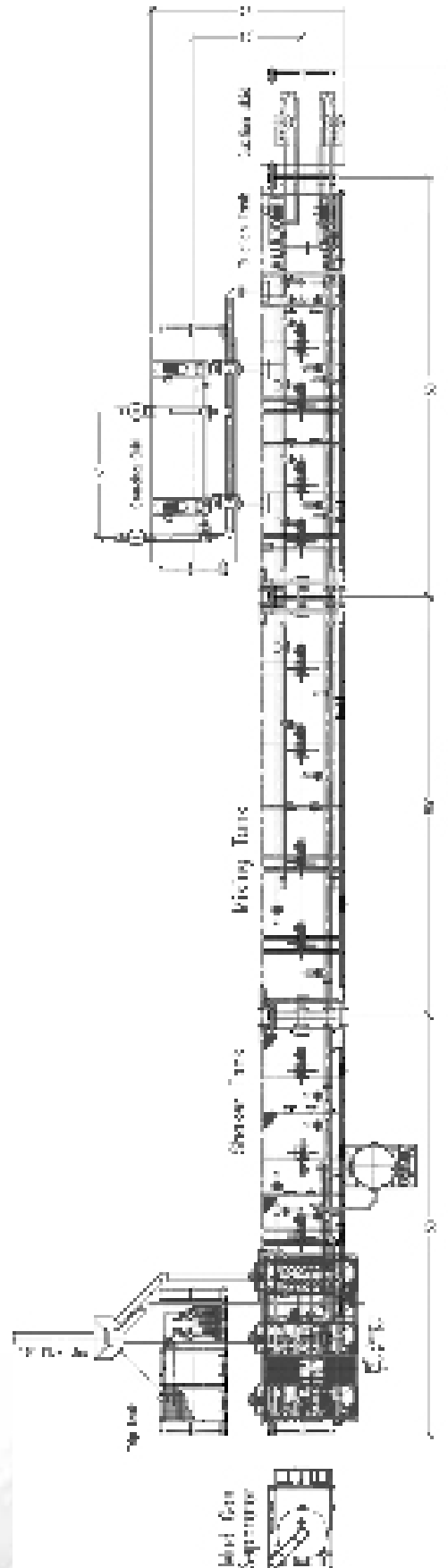

1500 bbl General Assembly Drawing

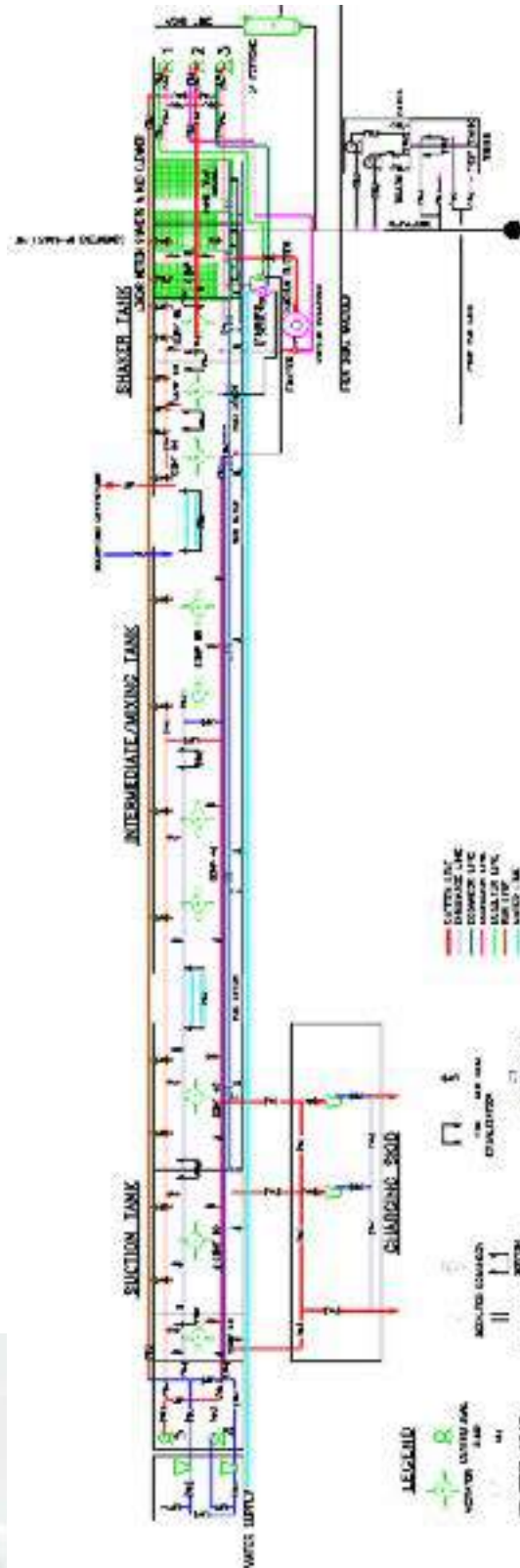

1500 bbl Flow Diagram

**SAM Systems (State of the Art Mud Systems)**

Our mud systems are designed by 21st Century Mud Engineers for 21st Century Applications. We can customized 250, 500, 1000 up to 5000 bbl mud systems.

**Basic Specifications:**

- Three(3) Tanks- 1500bbl Active Systems
  - One(1)500 bbl shaker tank on a 50" skid with four(4) compartments and one 10ft porch to accept three(3) 6x8 100hp centrifugal pumps.
  - Design Specifications: Overall Dimensions- 10'W x 9'6"H x 50'L ; one(1) 100bbl sand trap; one(1)133bbl degasser compartment; one(1) 133bbl desander compartment; one(1) 133bbl desilter compartment.
  - One(1) 632bbl intermediate/mixing tank on a 50' skid with two compartments.
  - Design Specifications: Overall Dimensions- 10'W x 9'6"H x 50'L; Two(2) 316bbl compartments.
  - One(1) 500bbl suction tank on a 10'W x 9'6"H x 50'L skid with three(3) compartments and one 10ft porch to accept two(2) 6x8 100hp centrifugal pumps.
  - Design Specifications: Overall Dimensions- 10'W x 9'6" H x 50'L; Two(2) 224bbl compartments ; one (1) 50 bbl slugging pit.

All steel is A36, all pipe is schedule 40; butterfly valves, hammer seal unions, hammer unions , required fittings and pipe; OSHA handrails with kick plates; Three I beam runner skid, crimped 1/4 " side walls with 3/8" floor. Mud ditch along top side of tanks from shakers to mixing tank with doors to discharge into each active system compartment. Sloped bottom tanks with 12" butterfly valve clean out doors and man ways with ladders in each compartment. All pumps outfitted with expansion couplings. Compartments have their overflow cut outs or equalizer valves.

100bbl Sand Trap with slanted bottom and 12" butterfly valve clean-out door.

6" x 6" x 1/2" ST mud rims; full galvanized grating where required , stairs, catwalks, full installation of equipment to tanks and skids prior to paint, full fit-up of tanks together, all required electrical mounts for tanks, Heavy duty folding outriggers in front of shaker and mud cleaner for easy access to equipment.

Equipment Installation/Handling : All equipment will be installed as required full piped; all skidded mud handling requirement will be disassembled from shaker tank for shipment to customer; agitators, pumps, and hopper left assembled.

Features:

Grating & Safety:

- Standard manhole covers for each compartment; External walkways will be stiffened and hinged to prevent distortion when retracting .
- Slots used for placement of handrails and walkways will be wide in order to accommodate some misalignment .
- All walkways to be hinged from the side of tanks and fold against side of tanks for transport.
- All folding walkways to include galvanized steel grating.

Electrical/Lighting (included in electrical rig-up)

Agitator starter mounts are included with ground lugs under each piece of equipment and two at each end of skids. Electrical trays on side of tank to support cable runs from equipment to starters and to power source.



API RP 13C Compliant

SCREEN PANELS

Our screen panels are available for most shale shakers. All screens are manufactured with high quality stainless steel wire mesh, and all wire cloth checked for conformance to tolerances and visually inspected for weaving flaws. Advanced manufacturing processes and a stringent quality assurance program ensures that only the highest quality screens are shipped. All screens and a wide range of screen meshes are API RP 13C -Compliant.



The floMAX D™ series screens are de-blinding screen panels that utilize a perforated support plate for added mesh support and reparability. The FMD series of screens are manufactured using ultra fine cloth square mesh and are available in mesh sizes from 24 to 450. As with all Fluid Systems, Inc. replacement screen frame panels, each screen is factory tensioned to eliminate improper tensioning in the field.



The flowMAX R™ screens consist of two layers of durable rectangle opening wire cloth above a heavy support cloth. The de-blinding characteristics of the three layer mesh configuration allows for better flow rate efficiency. The light weight frame allows for less screen flexing and more g-force transfer between screen and shaker basket. The diamond shaped openings in the screen frame prevent liquid channelling by distributing the flow evenly across the screen surface. The FMR series screen is manufactured using the powder coating adhesive process.

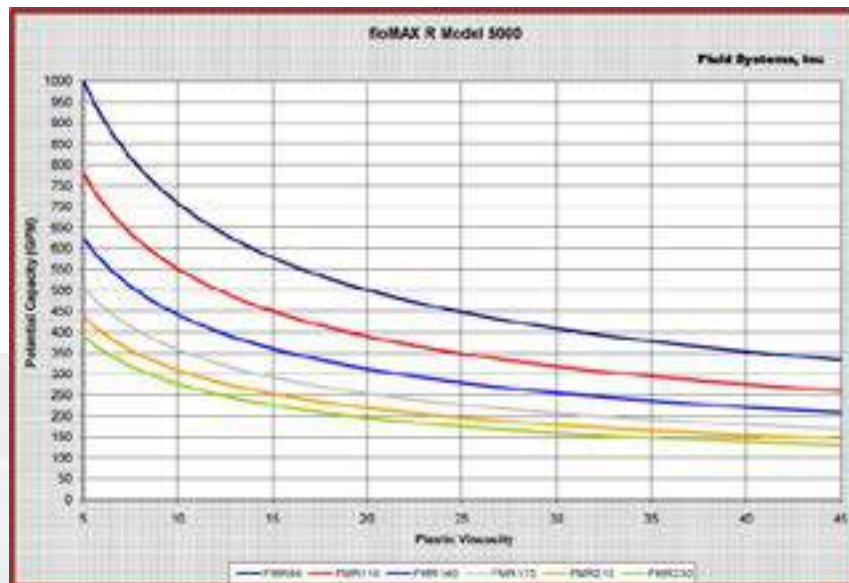
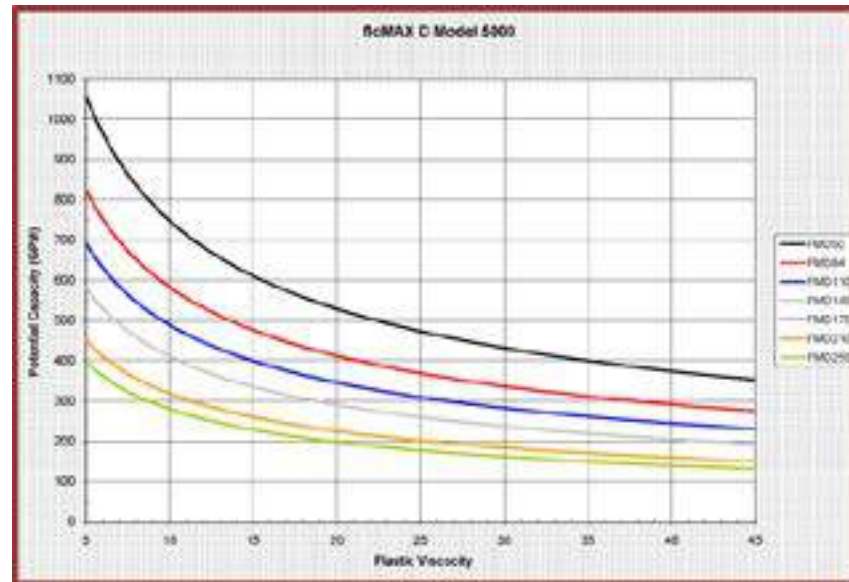

SCREEN PANELS

SEPARATION POTENTIAL				
Mesh	d100 µ m	API No.	O.A. %	Cond. kD/mm
A. FMD SERIES				
FMD 24	793	20	49.4	18.38
FMD 38	518	35	30.0	8.80
FMD 50	376	45	29.1	7.09
FMD 60	319	50	28.5	5.99
FMD 70	261	60	27.8	4.88
FMD 84	221	70	26.1	3.78
FMD 100	194	80	25.8	3.45
FMD 110	163	100	25.4	3.11
FMD 140	137	120	27.0	2.45
FMD 175	116	140	26.5	1.94
FMD 210	97	170	26.5	1.70
FMD 230	87	170	26.8	1.53
FMD 250	82	200	27.0	1.36
FMD 270	74	200	25.4	1.10
FMD 325	62	230	21.9	0.80
FMD 400	51	270	20.1	0.55
FMD 450	45	325	17.8	0.41
B. FMR SERIES				
FMR 24	1179	16	49.9	16.42
FMR 38	701	25	34.2	12.48
FMR 40	661	25	35.5	11.21
FMR 50	514	35	31.2	8.77
FMR 60	418	40	29.7	7.24
FMR 70	351	45	26.9	6.92
FMR 84	272	60	26.5	4.71
FMR 110	202	70	25.4	3.55
FMR 140	169	80	24.6	2.78
FMR 150	164	100	24.2	2.47
FMR 175	136	120	23.8	2.16
FMR 210	114	140	24.0	1.85
FMR 230	86	170	24.9	1.68
FMR 250	82	200	24.9	1.57
FMR 270	69	230	25.6	1.25
FMR 325	62	230	22.8	0.97
FMR 400	49	270	21.9	0.78
FMR 450	43	325	20.1	0.56
FMR 500	38	400	16.3	0.35

Our sophisticated design software can pinpoint the center of gravity of every screen panel model we manufacture to achieve balanced vibration. Every model had been designed for mechanical and structural configuration that can withstand linear, elliptical and circular motion. Our jigs & fixtures are well-maintained and

FSI's Screen Panel exhibits stability under varying G-Forces condition on all-points making it structurally stable and efficient compared to competitors framing which flexes irrationally. This point by point probe analysis of the two screen panels proved that FSI Screen Panels last longer and are structurally stable.

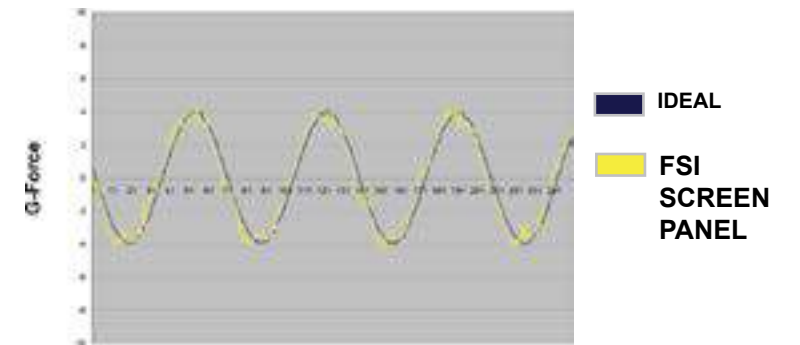

API RP 13C Compliant Label



\*d100 - Particles this size and larger will normally be discarded.  
 \*API - Corresponding API sieve equivalent as per API RP 13C  
 \*Cond. - Conductance - This represents the ease with which a liquid can flow through the screen. Larger values represent higher volume handling.